

LARP

LARP Phase II Secondary Rotatable Collimator

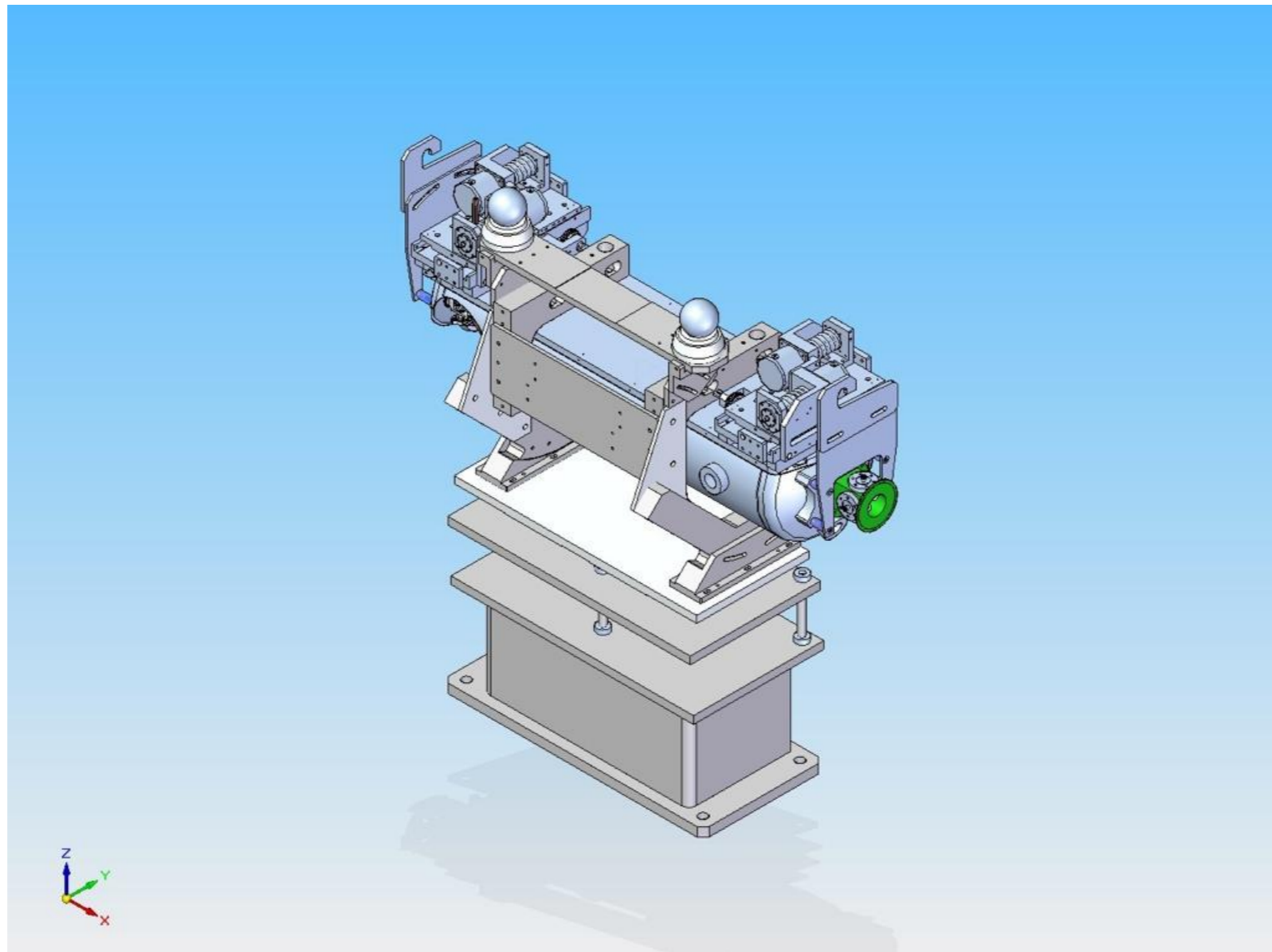

- 5 min. Status Report
- December 7th, 2009



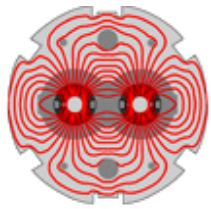

LARP

SPS Mounting

- Mounting, interconnects and orientation for SPS installation
- Being defined in Interface Document

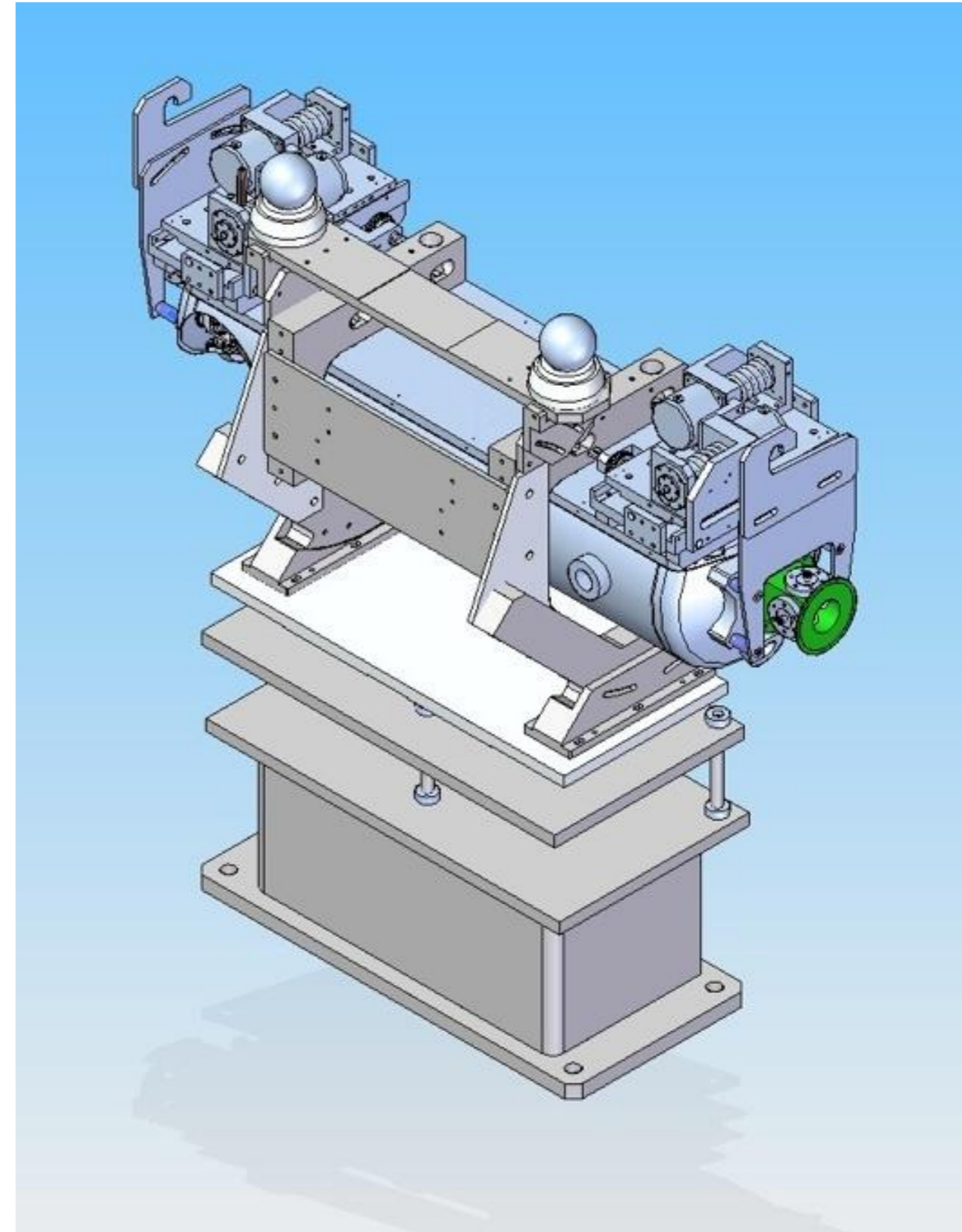
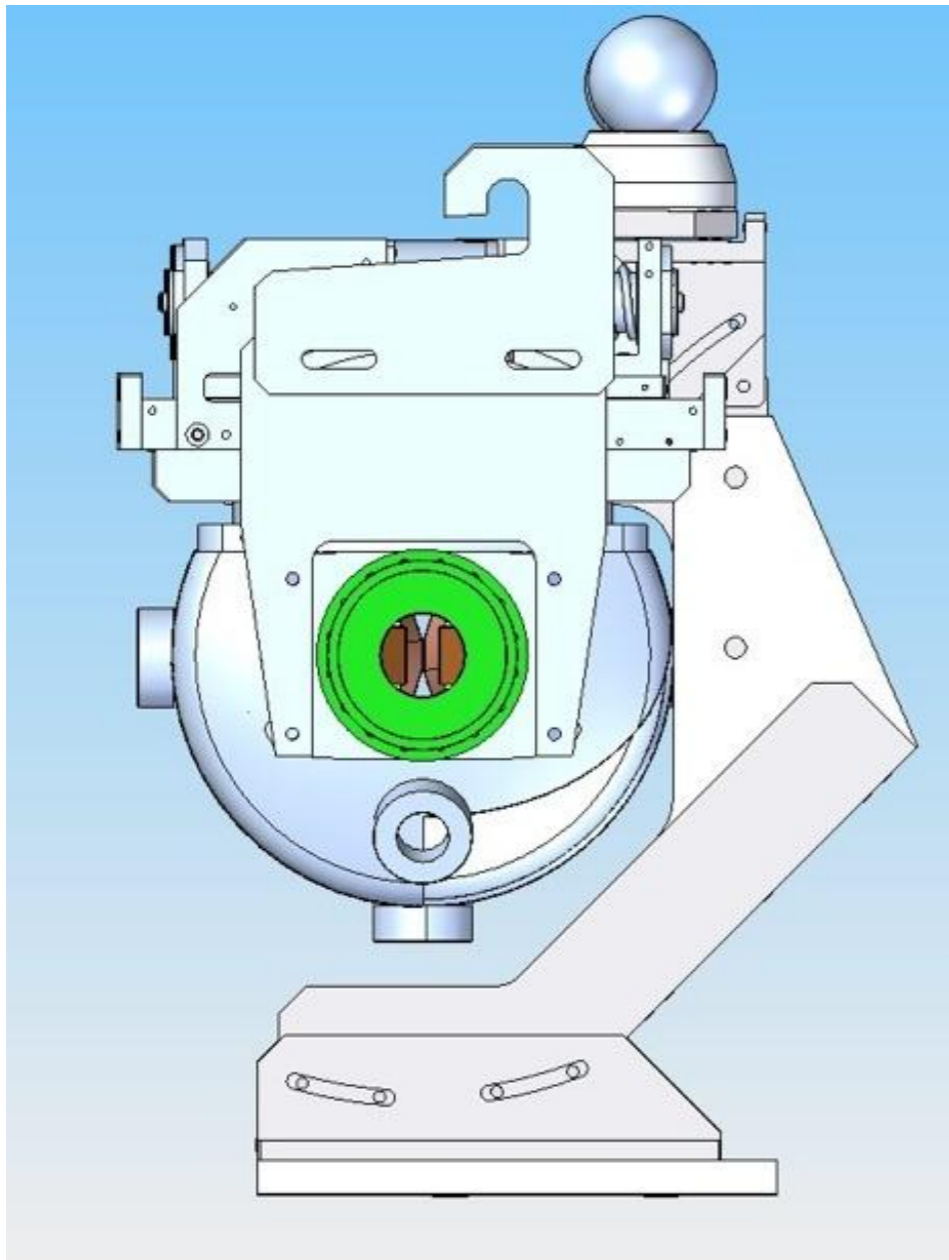

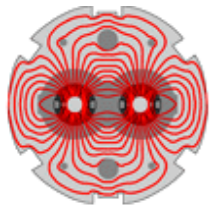

LARP

BPM Aperture

- It has now been established (hopefully final) that 60 mm circular diameter aperture is acceptable in SPS.
- Here is our final BPM profile and end flange.
- Parts to be made soon!

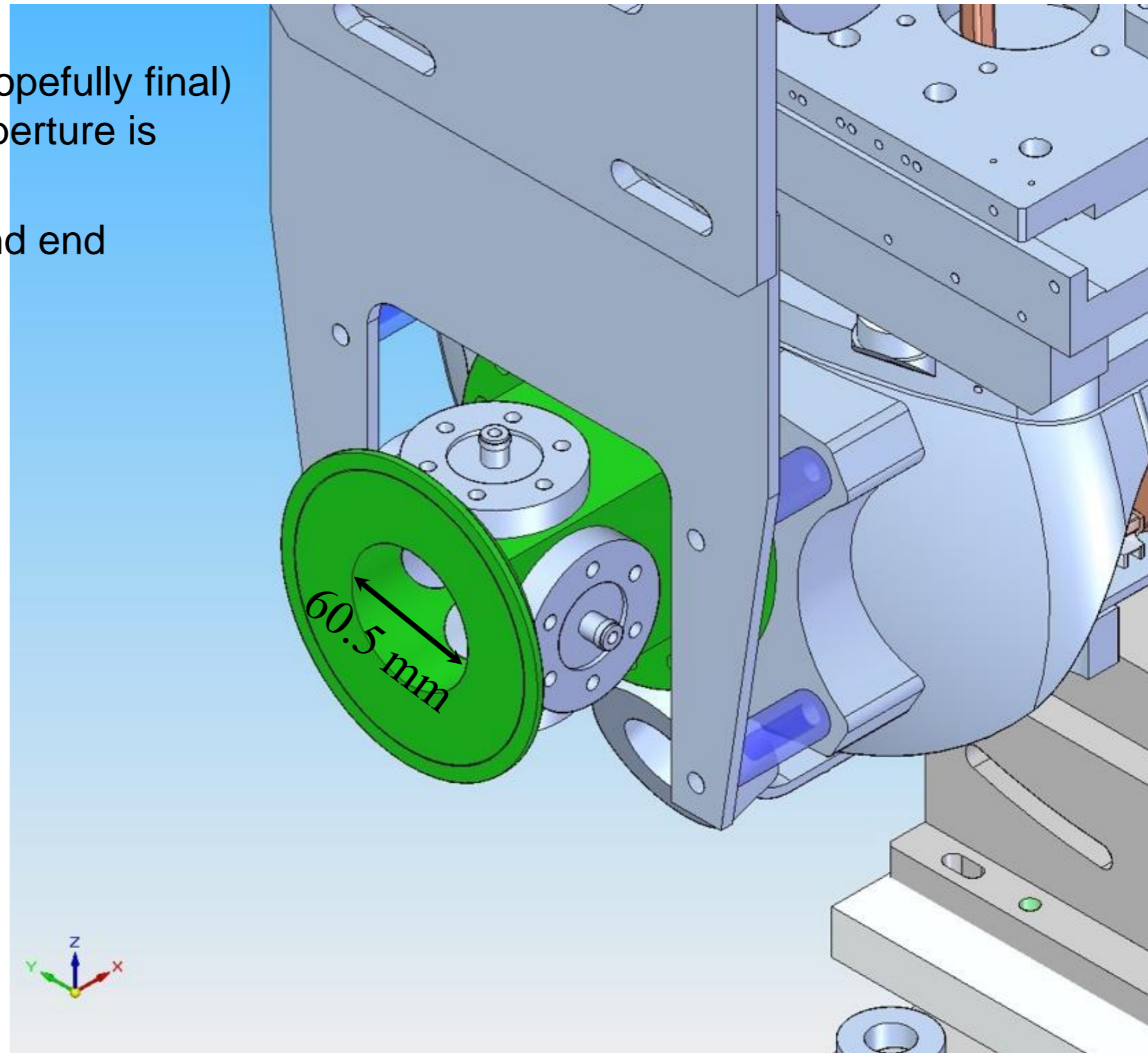

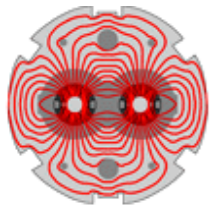

LARP

RC1 (second) Jaw Final Brazing Preparation

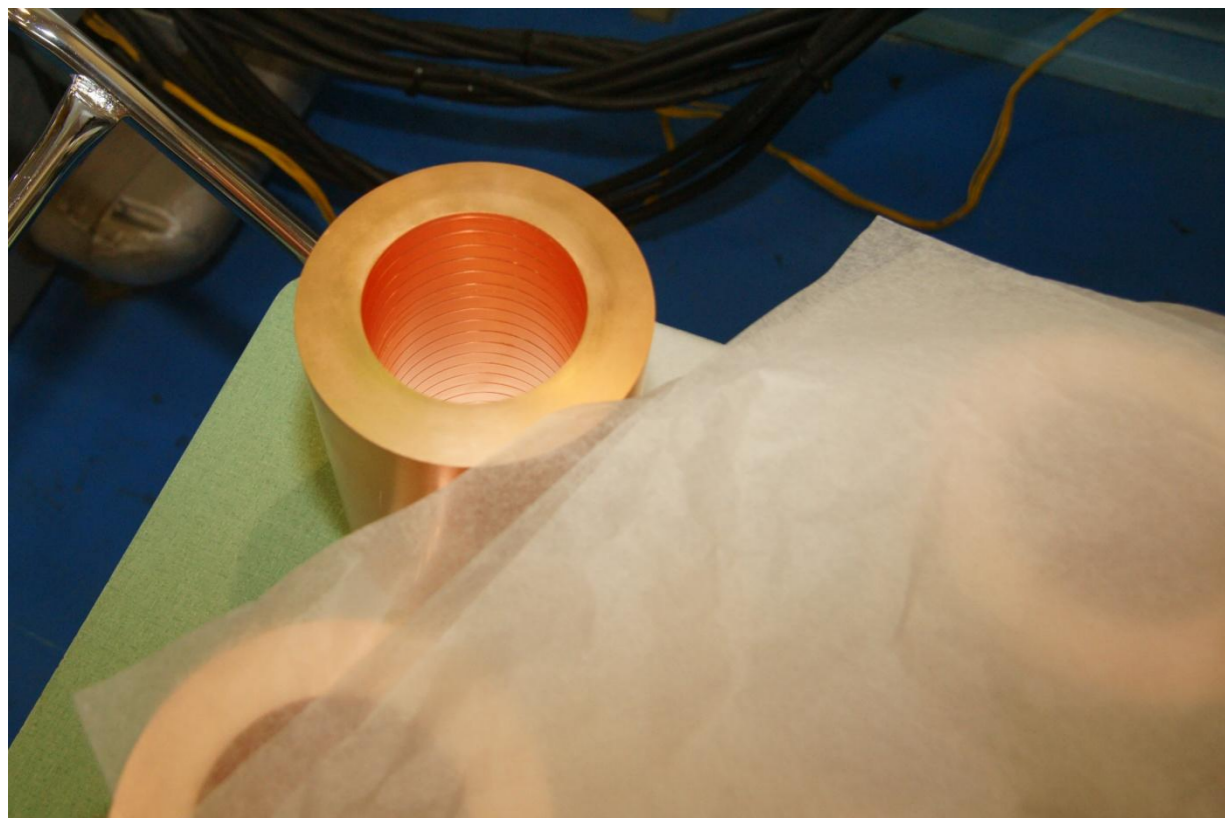
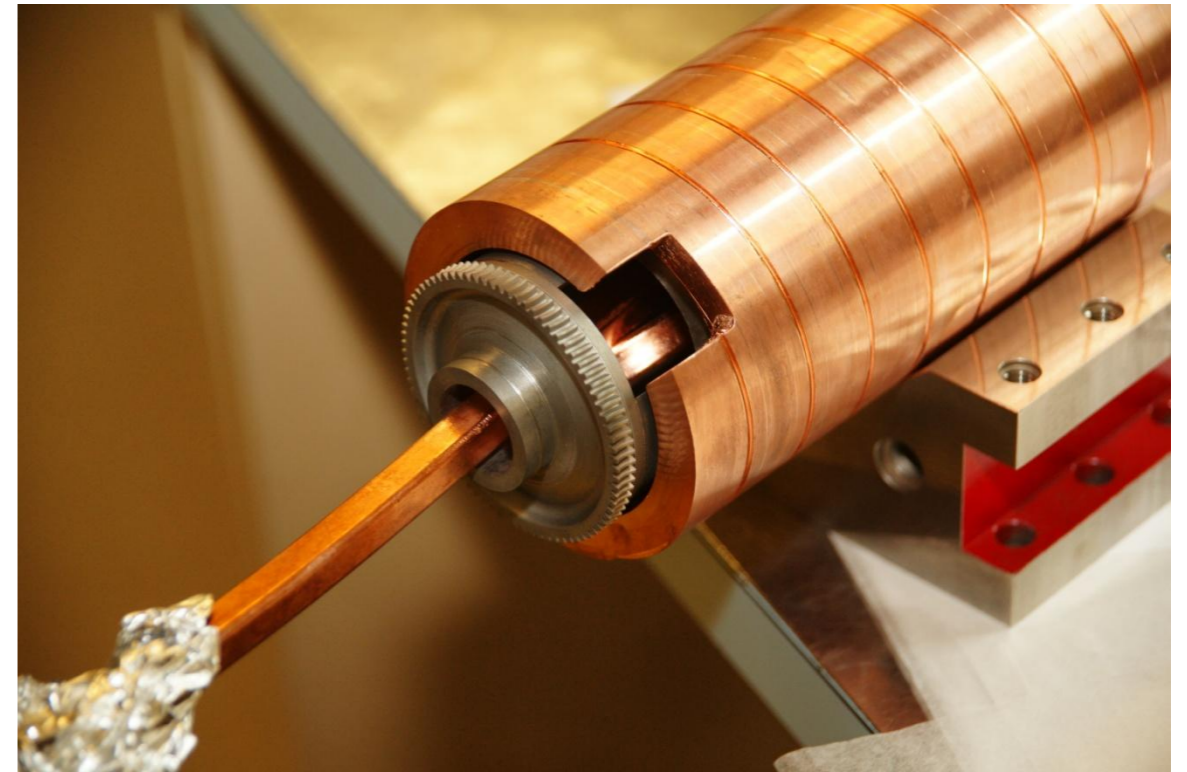

Mounting Jaw Cylinders

Mounting on stand



Sliding on Cylinders



Attached to Crane



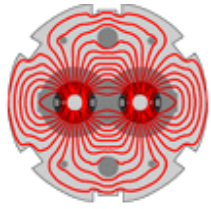

LARP

In oven pit

Brazing

Final Preparations

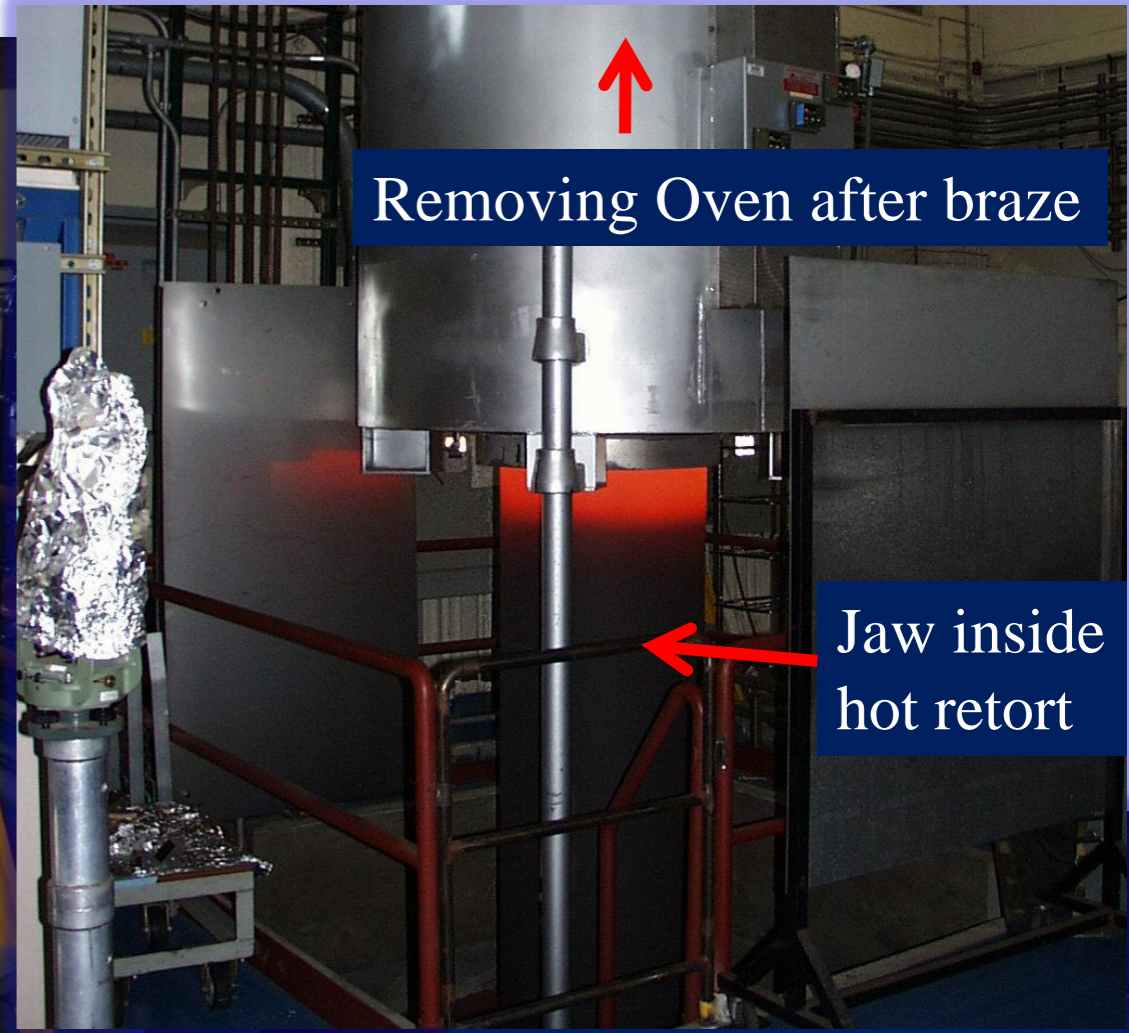

Removing Oven after braze

Jaw inside hot retort

Looking inside hot oven!



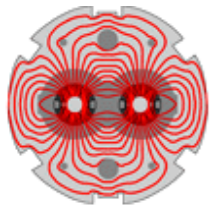

LARP

Results



- After cool-down retort removed.
- Braze looks good!

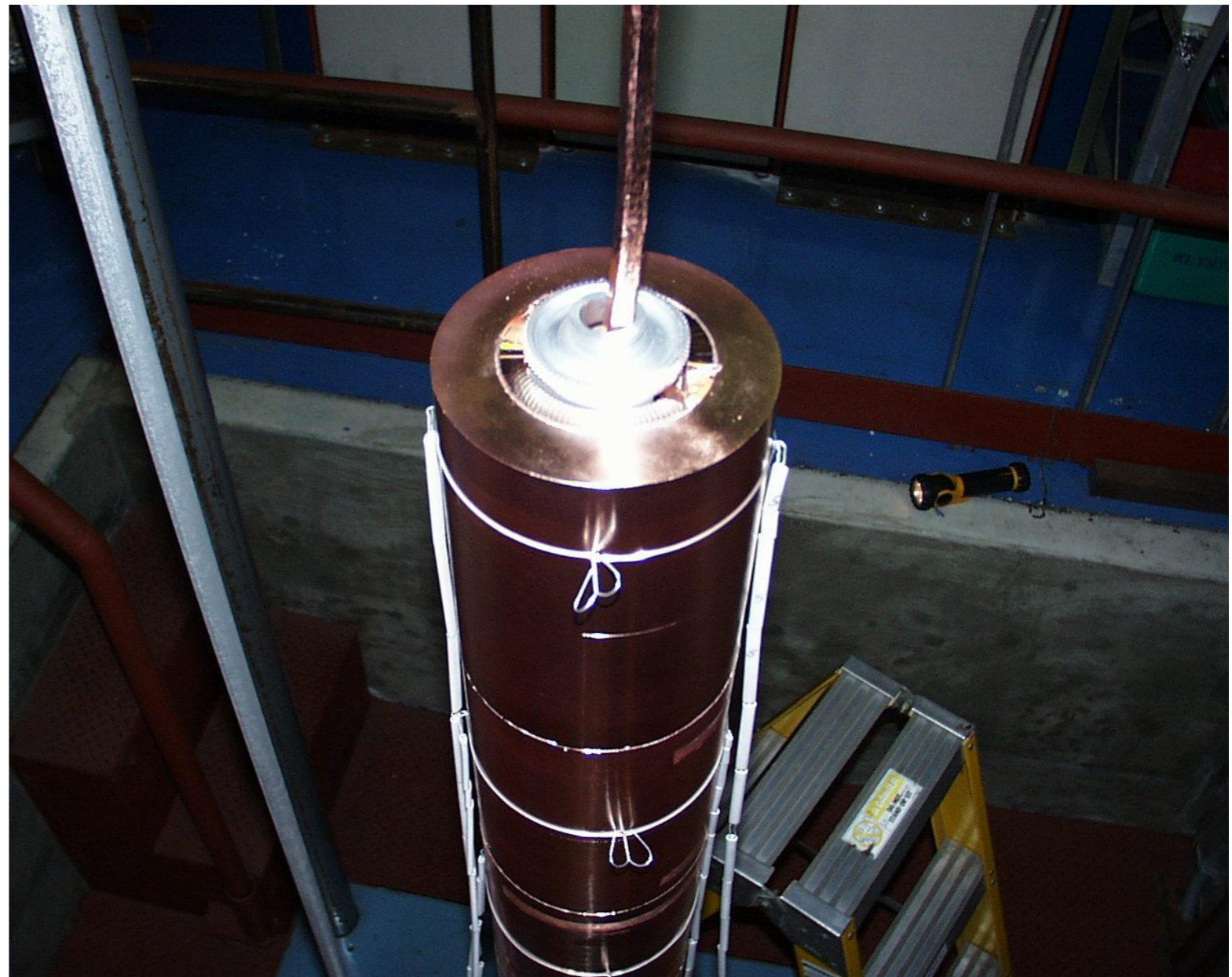

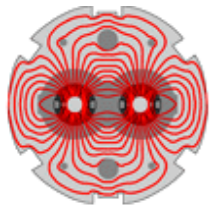

LARP

Vacuum Chamber and RC0



Vacuum chamber welded up



09 26 2000

Baseplate



09 26 2000

End parts for vacuum chamber



09 26 2000

RC0 (first) jaw final machining

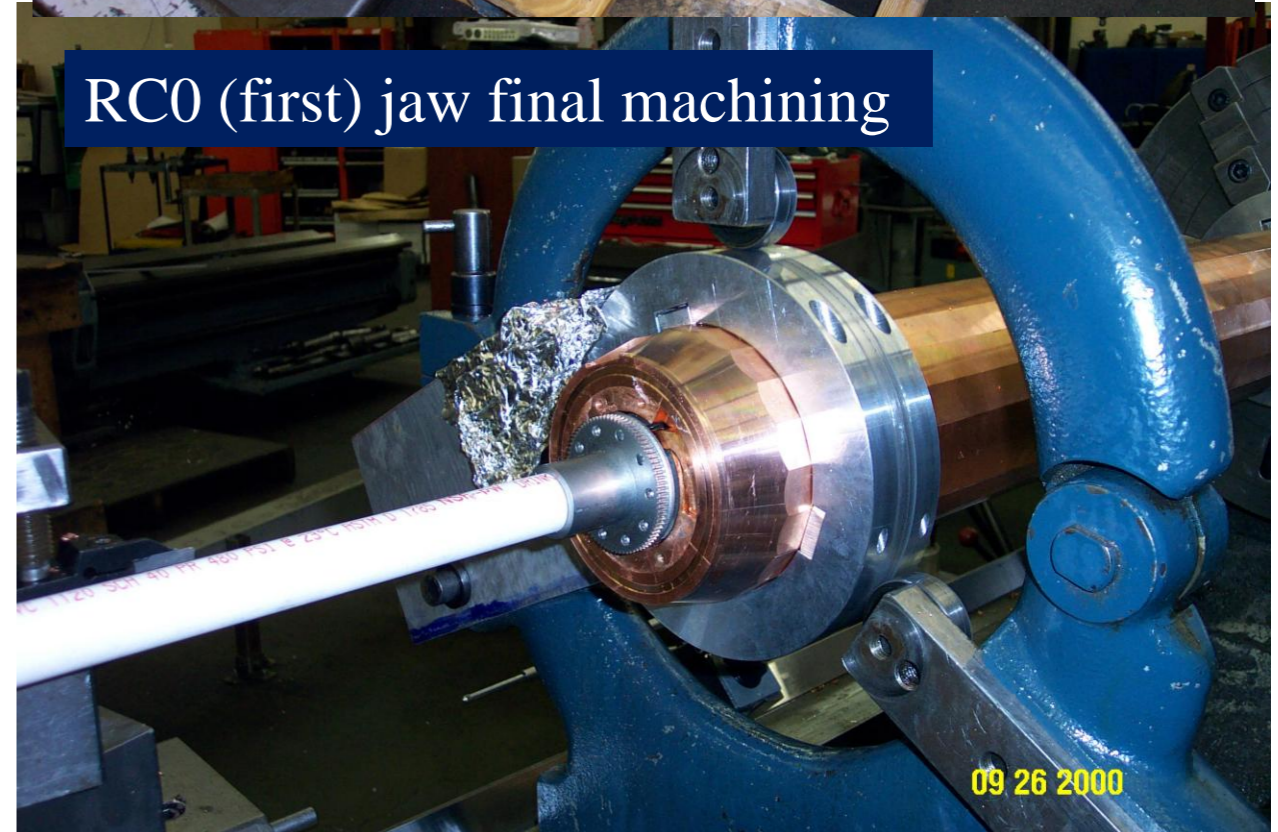

09 26 2000